

Typical Features

- ◆ Wide input voltage range 85-305VAC/100-430VDC
- ◆ No-load power consumption ≤0.3W
- ◆ Efficiency 86% (Typ.)
- ◆ Operating temperature from -40℃ to 85℃
- ◆ Switching frequency 65KHz (Typ.)
- ◆ Short Circuit, Over Current & Over Voltage protections
- ◆ Isolation voltage 4000VAC
- ◆ Altitude during operating 4000m Max
- ◆ With UL & TUV/CE certificates
- ◆ Safety Class: CLASS II



Application Field

FA15-220SXXG2N4 Series --- Compact size & high efficiency modular power supplies with global adapted input voltage range (both AC & DC available), low ripple, low temperature rise, low standby power consumption, high efficiency, high reliability and safety isolated. This series of products can be widely used in the fields of industry, office devices, electric power and household appliances, etc. The additional circuit for EMC is recommended in this data sheet for the application with high EMC requirement.

Typical Product List

Certificate	Part No.	Output Specification			Capacitive Load (Max)	Ripple & Noise 20MHz (Max)	Efficiency @full Load/ 220Vac
		Power	Voltage	Current			
		(W)	Vo (V)	Io (mA)			
UL/CB/CE	FA15-220S05G2N4	15	5	3000	5000	70	85
UL/CB/CE	FA15-220S12G2N4	15	12	1250	2000	120	85
UL/CB/CE	FA15-220S12V5G2N4	15	12.5	1200	2000	120	85
UL/CB/CE	FA15-220S15G2N4	15	15	1000	2000	120	85
UL/CB/CE	FA15-220S24G2N4	15	24	625	1000	120	86

Note 1 - The typical value of efficiency is based on the product tested after half an hour burn-in at full load.

Note 2 - The minimum efficiency is defined as -2% of the typical value.

Note 3 - Please contact Aipu sales for other output voltages requirement in this series but not listed in this table.

Note 4 - The suffix -T indicates a kind of chassis packaging, -TS indicates a kind of packaging of DIN Rail.

Input Specifications

Item	Operating Condition	Min.	Typ.	Max.	Unit
Input Voltage Range	AC Input	85	220	305	VAC
	DC Input	100	300	430	VDC
Input Frequency Range	-	47	50	63	Hz
Input Current	115VAC	-	-	0.45	A
	230VAC	-	-	0.3	

Surge Current	115VAC	-	-	30	A
	230VAC	-	-	60	
No Load Consumption	Input 115VAC	-	-	0.3	W
	Input 230VAC	-	-		
Leakage Current	-	0.5mA TYP/230VAC/50Hz			
External fuse recommended	2A/300VAC Time-delay fuse				
Hot plug	-	Unavailable			
Remote control terminal	-	Unavailable			

Output Specifications					
Item	Operating Condition	Min.	Typ.	Max.	Unit
Voltage Accuracy	Full input voltage Range, any load	-	-	±3.0	%
Line Regulation	Rated Load	-	-	±0.5	%
Load Regulation	Nominal input Voltage, 20%~100% load	-	-	±3.0	%
Minimum load	Single Output	0	-	-	%
Turn-on Delay Time	Input 115VAC (full load)	-	1000	-	mS
	Input 220VAC (full load)	-		-	
Power-off Hold up Time	Input 115VAC (full load)	-	100	-	mS
	Input 220VAC (full load)	-		-	
Dynamic Response	Overshoot range	25%~50%~25%	-	+5.0	%
	Recovery time				
Output Overshooting	Full input voltage range	≤10%Vo			%
Short Circuit Protection		Continuous, Self-recovery			Hiccup
Drift Coefficient	-	-	±0.03%	-	%/°C
Over Current Protection	Input 220VAC	≥120% Io, Self-recovery			Hiccup
Over Voltage Protection	Output 5VDC	≤7.5			VDC
	Output 12V/12.5V DC	≤18			
	Output 15VDC	≤20			
	Output 24VDC	≤30			
Noise & Ripple	-	-	-	120	mV
	The ripple and noise are tested by the twisted pair method. For detailed understood, please refer to the following Ripple & Noise Test Instructions.				

General Specifications

Item	Operating Condition	Min.	Typ.	Max.	Unit
Switching Frequency	-	61	65	73	KHz
Operating Temperature	Refer to the temperature derating curve	-40	-	+85	°C
Storage Temperature	-	-40	-	+90	
Soldering Temperature	Wave-soldering	260±4°C, timing 5-10S			
	Manual-soldering	360±8°C, timing 4-7S			
Relative Humidity	-	10	-	90	%RH
Isolation Voltage	I/P-O/P, Test 1min, leakage current ≤5mA	4000	-	-	VAC
Insulation Resistance	I/P-O/P @DC500V	100	-	-	MΩ
Vibration	-	10-55Hz,10G,30Min, along X,Y,Z			
Safety Class	-	CLASS II			
MTBF	-	MIL-HDBK-217F@25°C>300,000H			
Product Weight	Part No.	Weight (Typ.)			
	FA15-220SXXG2N4	50g			
	FA15-220SXXG2N4-T	65g			
	FA15-220SXXG2N4-TS	85g			

EMC Performance

Total item	Sub item	Test Standard	Performance/Class	
EMC	EMI	CE	CISPR32/EN55032 CLASS B (with Recommended Circuit 1)	
		RE	CISPR32/EN55032 CLASS B (with Recommended Circuit 1)	
	EMS	ESD	IEC/EN61000-4-2	Contact ±6KV / Air ±8KV Perf.Criteria B
		RS	IEC/EN61000-4-3	10V/m Perf.Criteria A
		EFT	IEC/EN61000-4-4	±2KV Perf.Criteria B
			IEC/EN61000-4-4	±4KV Perf.Criteria A (with Recommended Circuit 1)
		Surge	IEC/EN61000-4-5	Line to line ±1KV Perf.Criteria B
			IEC/EN61000-4-5	Line to line ±2KV / line to ground ±4KV Perf.Criteria A (with Recommended Circuit 1)
		CS	IEC/EN61000-4-6	10Vr.m.s Perf.Criteria A
		PFMF	IEC/EN61000-4-8	10A/m Perf.Criteria A
Voltage dips and interruptions	IEC/EN61000-4-11	0%-70% Perf.Criteria B		

Mechanical Dimensions

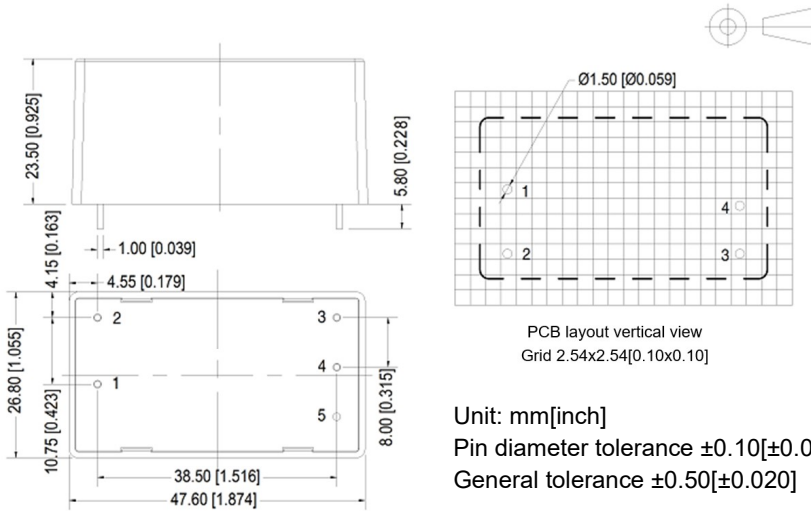

Pin No.	Function
1	AC(L)
2	AC(N)
3	-Vout
4	+Vout
5	No Pin

(-T) Mechanical Dimensions

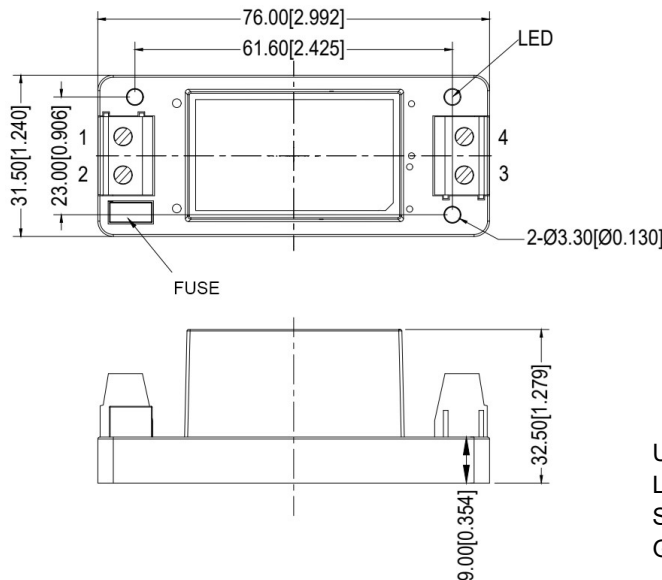

Terminal No.	Function
1	AC(L)
2	AC(N)
3	-Vout
4	+Vout

(-TS) Mechanical Dimensions

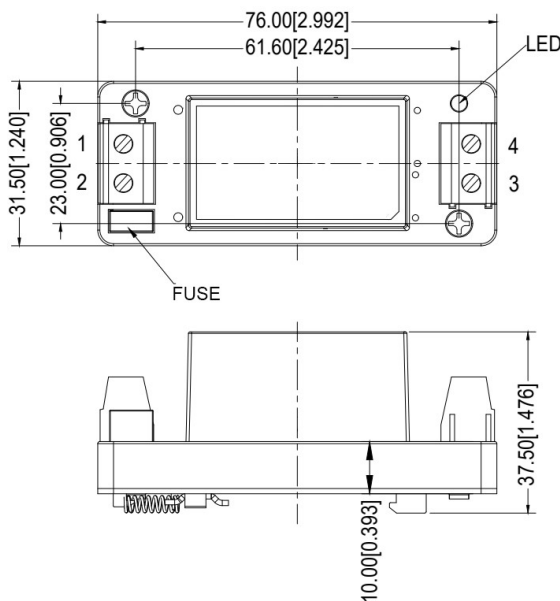

Terminal No.	Function
1	AC(L)
2	AC(N)
3	-Vout
4	+Vout

Packaging Code	Dimensions L x W x H	
-	47.60 x 26.8 x 23.50 mm	1.874 x 1.055 x 0.925 inch
-T	76.00 x 31.50 x 32.50 mm	2.992 x 1.240 x 1.279 inch
-TS	76.00 x 31.50 x 37.50 mm	2.992 x 1.240 x 1.476 inch

Ripple & Noise Test Instructions (Twisted Pair Method, 20MHz Bandwidth)

1) The Ripple & noise test needs 12# twisted pair cables, an oscilloscope which bandwidth should be set to 20MHz, 0.1uF polypropylene capacitor and 10uF high-frequency low-resistance electrolytic capacitor are connected in parallel with the probes (100M bandwidth). The oscilloscope should be set at the Sample Mode.

2) The test diagram is shown on the right. The converter output connects to the electronic load by the jig with cables which size should be defined according to the output current value. The twisted pair (length 30cm±2 cm) should be connected in parallel with the load, the location is as close as possible to the output pins or terminals. The test can be started after input power on.

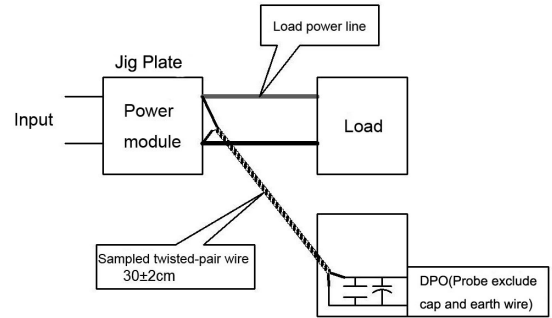

Product Performance Curves

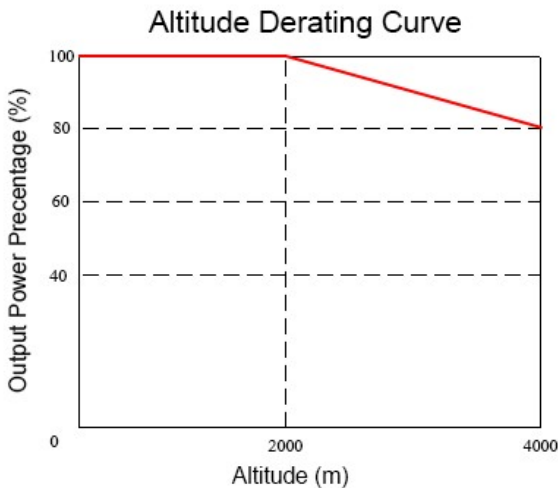
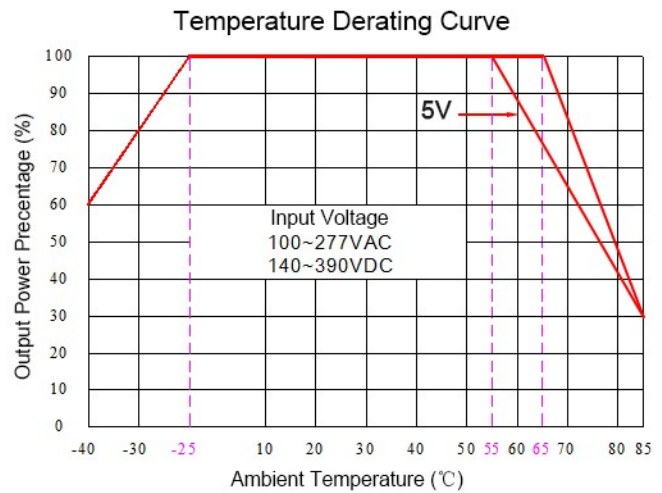
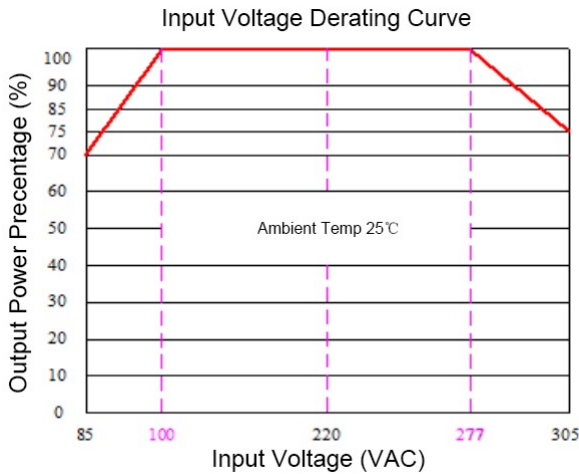

Note 1 - The output power should be derated based on the input voltage derating curve at 85~100VAC/277~305VAC/120~140VDC/390~430VDC.

Note 2 - This product should operate at a natural air condition, please contact us if it need be used at a closed space.

Recommended Circuit for Application

1, EMC Solution and Recommend Circuit

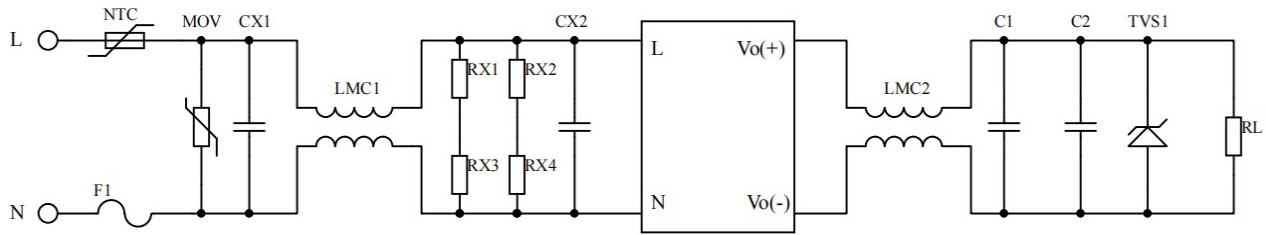

Circuit 1

- Note:
1. 2A~300Vac time-delay fuse is recommended.
 2. 14D561K/3500A is recommended for MOV.
 3. 10D-11 NTC is recommended to protect the converter against the lightning surges.
 4. 30mH/0.6A CMC is recommended for LCM1, 40uH/4A CMC for LCM2.
 5. X capacitor X2/224K/310Vac is recommended for CX1, X2/104K/310Vac for CX2.
 6. 1206,1MΩ,1/4W SMD resistors are recommended for RX1, RX2, RX3, RX4.
 7. C1 capacitance value should be less than the Max capacitive load, a high frequency low impedance electrolytic capacitor is recommended, its withstand voltage should be more than 1.5X of output voltage.
 8. 0.1uF ceramic SMD capacitor is recommended for C2 which withstand voltage should be more than 1.5X of output voltage.
 9. TVS1 - SMBJ7.0A is recommended for 5V output, SMBJ12.0A for 9V output, SMBJ20A for 12V & 15V outputs, SMBJ30.0A for 24V output and SMBJ64A for 48V output.

2, External Circuit to improve Ripple for FA15-220S05G2N4

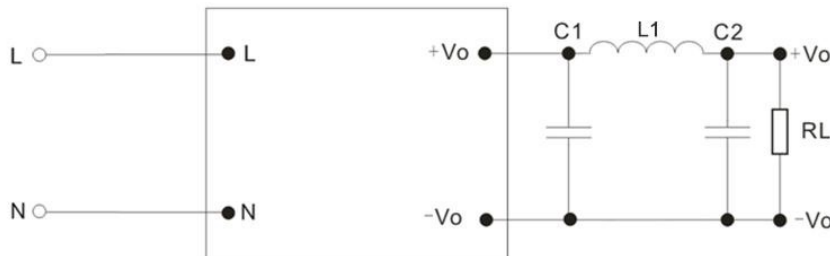

Circuit 2

- Note:
1. Electrolytic capacitors 330uF/10V is recommended for C1 and 220uF/10V for C2
 2. 2.2uH Drum choke is recommended for L1, which wound wire diameter should be at least Ø0.7mm.

Application Notice

1. The products should be used according to the specifications in this datasheet, otherwise it could be permanently damaged.
2. The product performance in this datasheet cannot be guaranteed if it works at a lower load than the minimum load defined.
3. The product performance in this datasheet cannot be guaranteed if it works under over-load condition.
4. Unless otherwise specified, all values or indicators in this datasheet are tested at $T_a=25^{\circ}\text{C}$, humidity<75%RH, rated input voltage and rated load (pure resistance load).
5. All values or indicators in this datasheet had been tested based on Aipupower test specifications.
6. The specifications are specially for the parts listed in this datasheet, any other non-standard model performances could be out of the specifications. Please contact our technician for specific requirements.
7. Aipupower can provide customization service.

Guangzhou Aipu Electron Technology Co., Ltd

Address: Building 4, HEDY Park, No.63, Punan Road, Huangpu Dist, Guangzhou, China.

Tel: 86-20-84206763 Fax: 86-20-84206762 HOTLINE: 400-889-8821

E-mail: sales@aipu-elec.com Website: <https://www.aipupower.com>